

FLEXIBLE DUCT

ALUDEC - 45



Description

ALUDEC Standard are fully flexible, light weight, uninsulated, laminated ducts suitable for low and high pressure systems. The ducts consist of several layers of aluminum and polyester laminates encapsulating a high tensile steel wire helix. Aludec flexible ducts are easily installed over either round or oval connections. At high temperature, or in case of fire, no toxic or gas emission.

Ordering

Product Code: ALUDEC-45 - aaa

Type _____
 diameter _____

Construction and Dimensions

Construction:

ALUDEC ducts constructed out of a "sandwich construction" laminates. This means the different layers of aluminum and polyester are overlapping each other completely and encapsulates a high tensile steel wire. The multiple laminates are adhered with fire retardant thermosetting adhesive.

Diameter:

All standard diameters ranging from 102mm to 508mm.

Wire Spacing:

All sizes 36 mm.

Wire:

3 thickness of wire are used:
 0.9mm, from dia. 102mm - 178mm
 1.2mm, from dia. 203mm - 315mm
 1.6mm, from dia. 356mm - 508mm

Chemical Resistance:

- Good resistance to many solvents
- Moderate resistance to acid & base

Applications:

Aludec are appropriate for applications of general air supply and airconditioning systems.

Mechanical and Technical Data

Minimum Bending Radius:

0.58 x Ø

Temperature Range:

-30 °C to + 140 °C

Air Velocity:

Max. 30 m/s (5900 ft/min)

Working Pressure:

Max. 250mm WG (2500 Pa. or 10 inch WG)

Standard Color:

Aluminum

Fire Class:

Please see schedule on page 274.

Packing

Dia. Range		Std. Length (meters)	Carton Size (mm)
(mm)	(inches)		
102 - 305	(4"- 12")	10 meters	350 x 350 x 600
355	(14")	10 meters	350 x 350 x 750
405	(16")	10 meters	500 x 500 x 750
457	(18")	10 meters	500 x 500 x 750

Standard Length:

10 meters for all sizes

ALUDEC - 70



Description

ALUDEC Prime are fully flexible, light weight, uninsulated, laminated ducts suitable for low and high pressure systems. The ducts consist of several layers of aluminum and polyester laminates encapsulating a high tensile steel wire helix. Aludec flexible ducts are easily installed over either round or oval connections. At high temperature, or in case of fire, no toxic or gas emission.

Ordering

Product Code: ALUDEC-70 - aaa

Type _____
 diameter _____

Construction and Dimensions

Construction:

ALUDEC ducts constructed out of a "sandwich construction" laminates. This means the different layers of aluminum and polyester are overlapping each other completely and encapsulates a high tensile steel wire. The multiple laminates are adhered with fire retardant thermosetting adhesive.

Diameter:

All standard diameters ranging from 102mm to 508mm.

Wire Spacing:

All sizes 25mm.

Wire:

3 thickness of wire are used:
 0.9mm, from dia. 102mm - 178mm
 1.2mm, from dia. 203mm - 315mm
 1.6mm, from dia. 356mm - 508mm

Chemical Resistance:

- Good resistance to many solvents
- Moderate resistance to acid and base

Applications:

Aludec are appropriate for applications of general air supply & airconditioning systems.

Mechanical and Technical Data

Minimum Bending Radius:

0.58 x Ø

Temperature Range:

-30 °C to + 140 °C

Air Velocity:

Max. 30 m/s (5900 ft/min)

Working Pressure:

Max. 300mm WG (3000 Pa. or 12 inch WG)

Standard Color:

Aluminum

Fire Class:

Please see schedule on page 274.

Packing

Dia. Range		Std. Length (meters)	Carton Size (mm)
(mm)	(inches)		
102 - 305	(4"- 12")	10 meters	350 x 350 x 600
355	(14")	10 meters	350 x 350 x 750
405	(16")	10 meters	500 x 500 x 750
457	(18")	10 meters	500 x 500 x 750

Standard Length:

10 meters for all sizes

ALUDEC - A



Description

ALUDEC - A are fully flexible, light weight, uninsulated, laminated ducts suitable for low and high pressure systems. The ducts consist of several layers of aluminized polyester laminates encapsulating a high tensile steel wire helix. ALUDEC flexible ducts are easily installed over either round or oval connections. At high temperature, or in case of fire, no toxic or gas emission.

Ordering

Product Code: ALUDEC-A - aaa

Type _____
diameter _____

Construction and Dimensions

Construction:

ALUDEC ducts constructed out of a "sandwich construction" laminates. This means the different layers of aluminized polyester are overlapping each other completely and encapsulates a high tensile steel wire. The multiple laminates are adhered with fire retardant thermosetting adhesive.

Diameter:

All standard diameters ranging from 102mm to 508mm.

Wire Spacing:

All sizes 36 mm.

Wire:

3 thickness of wire are used:
0.9mm, from dia. 102mm - 178mm
1.2mm, from dia. 203mm - 315mm
1.6mm, from dia. 356mm - 508mm

Chemical Resistance:

- Good resistance to many solvents
- Moderate resistance to acid and base

Applications:

Aludec are appropriate for applications of general air supply and airconditioning systems.

Mechanical & Technical Data

Minimum Bending Radius:

0.54 x Ø

Temperature Range:

-20 °C to + 120 °C

Air Velocity:

Max. 30 m/s (5900 ft/min)

Working Pressure:

Max. 300mm WG (3000 Pa. or 12 inch WG)

Standard Color:

Aluminum

Packing

Dia. Range		Std. Length (meters)	Carton Size (mm)
(mm)	(inches)		
102 - 305	(4" - 12")	10 meters	350 x 350 x 600
355	(14")	10 meters	350 x 350 x 750
405	(16")	10 meters	500 x 500 x 750
457	(18")	10 meters	500 x 500 x 750

Standard Length:

10 meters for all sizes

Description

ISODEC ducts is fully flexible high quality thermally insulated ducts for various purposes. The ducts consist of an ALUDEC inner core shielding the fiberglass insulation from the airstream with a tough outerjacket/vapour barrier constructed of multiple layer of aluminum laminated construction and reinforced with fiberglass. The ducts are easily installed over either round or oval connection.

Ordering

Product Code: ISODEC-25 - aaa

Type _____
diameter _____

ISODEC - 25



Construction and Dimensions

Inner Core:

ALUDEC standard

Insulation

25mm thick highly efficient fiberglass with a density of 16kg/m³.

50mm thick insulation also available upon request.

Vapour Barrier:

A durable, scuff resistant outerjacket made of strong very tough spirally reinforced multiple layer aluminum laminated construction.

Diameter Range:

All standard diameters ranging from 102mm to 457mm.

Chemical Resistance:

- Good resistance to many solvents
- Moderate resistance to acid and base

Applications:

ISODEC are appropriate for applications of general air supply and airconditioning systems.

Mechanical and Technical Data

Minimum Bending Radius:

0.54 x Ø

Thermal Conductivity

0.04 W/mK

Temperature Range:

-30 °C to + 140 °C

Air Velocity:

Max. 25 m/s (4900 ft/min)

Working Pressure:

Max. 250mm (2500 Pa. or 10 inch WG)

Standard Color:

Aluminum

Fire Class:

Please see schedule on page 274.

Packing

Dia. Range		Std. Length (meters)	Carton Size (mm)
(mm)	(inches)		
102 - 305	(4" - 12")	10 meters	350 x 350 x 600
355	(14")	10 meters	350 x 350 x 750
405	(16")	10 meters	500 x 500 x 750
457	(18")	10 meters	500 x 500 x 750

Standard Length:

10 meters for all sizes (except 18" dia. L = 5M)

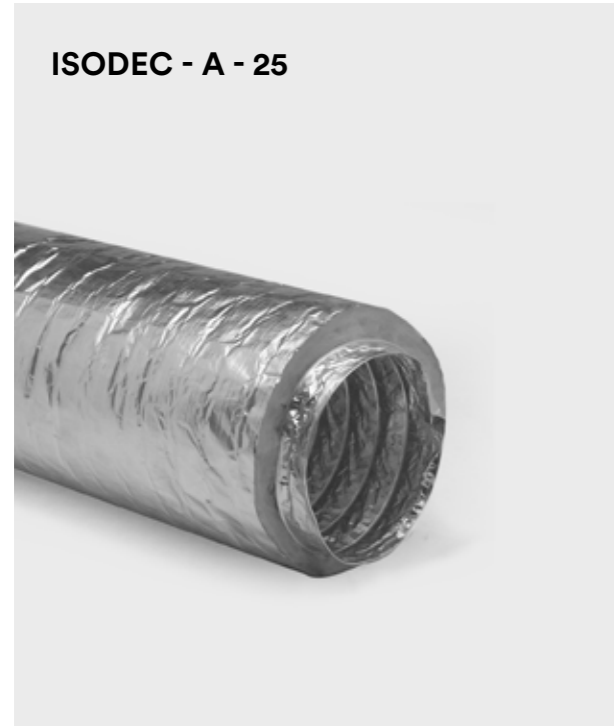

ISODEC - A - 25

Description

ISODEC - A ducts are fully flexible high quality thermally insulated ducts for various purposes. The ducts consist of an ALUDEC inner core shielding the fiberglass insulation from the airstream with a tough outerjacket/vapour barrier constructed of multiple layer of aluminum laminated construction and reinforced with fiberglass. The ducts are easily installed over either round or oval connection.

Ordering

Product Code: ISODEC-A - aaa
 Type _____
 diameter _____

Construction and Dimensions

Inner Core:
ALUDEC standard

Insulation:
25mm thick highly efficient fiberglass with a density of 16kg/m³.
50mm thick insulation also available upon request.

Vapour Barrier:
A durable, scuff resistant outerjacket made of strong very tough spirally reinforced multiple layer aluminum laminated construction.

Diameter Range:
All standard diameters ranging from 102mm to 457mm.

Chemical Resistance:
• Good resistance to many solvents
• Moderate resistance to acid and base

Applications:
ISODEC are appropriate for applications of general air supply and airconditioning systems.

Temperature Range:
-20 °C to + 130 °C

Air Velocity:
Max. 25 m/s (4900 ft/min)

Working Pressure:
Max. 250mm WG (2500 Pa. or 10 inch WG)

Standard Color:
Aluminum

Packing

Dia. Range		Std. Length (meters)	Carton Size (mm)
(mm)	(inches)		
102-305	(4"- 12")	10 meters	350 x 350 x 600
355	(14")	10 meters	350 x 350 x 750
405	(16")	10 meters	500 x 500 x 750
457	(18")	10 meters	500 x 500 x 750

Standard Length:
10 meters for all sizes (except 18" dia. L = 5M)

Mechanical and Technical Data

Minimum Bending Radius:
0.54 x Ø

Thermal Conductivity:
0.04 W/mK

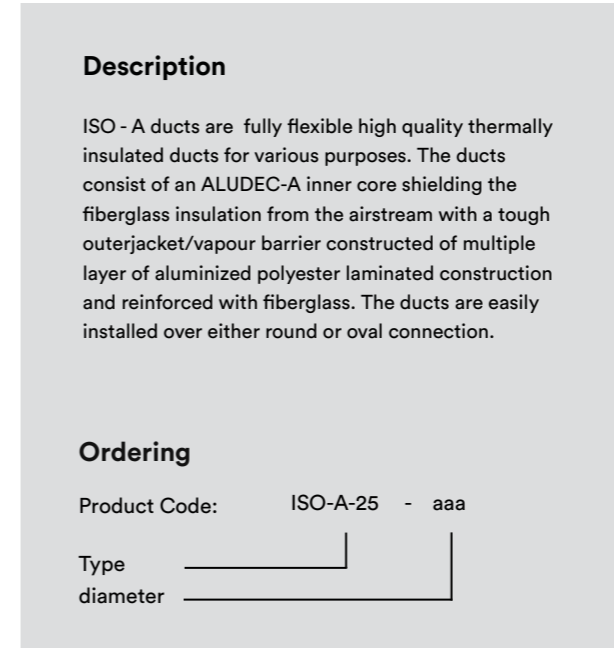

ISO - A - 25

Description

ISO - A ducts are fully flexible high quality thermally insulated ducts for various purposes. The ducts consist of an ALUDEC-A inner core shielding the fiberglass insulation from the airstream with a tough outerjacket/vapour barrier constructed of multiple layer of aluminized polyester laminated construction and reinforced with fiberglass. The ducts are easily installed over either round or oval connection.

Ordering

Product Code: ISO-A-25 - aaa
 Type _____
 diameter _____

Construction and Dimensions

Inner Core:
ALUDEC-A

Insulation:
25mm thick highly efficient fiberglass with a density of 16kg/m³.
50mm thick insulation also available upon request.

Vapour Barrier:
A durable, scuff resistant outerjacket made of strong very tough spirally reinforced multiple layer aluminized polyester construction.

Diameter Range:
All standard diameters ranging from 102mm to 457mm.

Chemical Resistance:
• Good resistance to many solvents
• Moderate resistance to acid and base

Applications:
ISO-A are appropriate for applications of general air supply and airconditioning systems.

Mechanical and Technical Data

Minimum Bending Radius:
0.54 x Ø

Thermal Conductivity
0.04 W/mK

Temperature Range:
-20 °C to + 120 °C

Air Velocity:
Max. 25 m/s (4900 ft/min)

Working Pressure:
Max. 250mm WG (2500 Pa. or 10 inch WG)

Standard Color:
Aluminum

Fire Class:
Please see schedule on page 274.

Packing

Dia. Range		Std. Length (meters)	Carton Size (mm)
(mm)	(inches)		
102 - 305	(4"- 12")	10 meters	350 x 350 x 600
355	(14")	10 meters	350 x 350 x 750
405	(16")	10 meters	500 x 500 x 750
457	(18")	10 meters	500 x 500 x 750

Standard Length:
10 meters for all sizes (except 18" dia. L = 5M)

SONODEC - 25



Description

SONODEC ducts are fully flexible high quality thermally and acoustically insulated ducts for various purposes. The ducts consist of perforated type ALUDEC standard inner core shielding the fiberglass insulation from the airstream with a tough outerjacket/vapour barrier constructed of multiple layer of aluminum laminated construction and reinforced with fiberglass. The ducts are easily installed over either round or oval connection.

Ordering

Product Code: SONODEC-25 - aaa

Type _____
diameter _____

Construction and Dimensions

Inner Core:
Perforated ALUDEC standard

Insulation:
25mm thick highly efficient fiberglass with a density of 16kg/m³.

50mm thick insulation also available upon request.

Vapour Barrier:
A durable, scuff resistant outerjacket made of strong very tough spirally reinforced multiple layer aluminum laminated construction.

Diameter Range:
All standard diameters ranging from 102mm to 457mm.

Chemical Resistance:

- Good resistance to many solvents
- Moderate resistance to acid and base

Applications:
SONODEC are appropriate for applications of general air supply and airconditioning systems.

Mechanical and Technical Data

Minimum Bending Radius:
0.54 x Ø

Thermal Conductivity:
0.04 W/mK

Temperature Range:
-30 °C to + 140 °C

Air Velocity:
Max. 30 m/s (5900 ft/min)

Working Pressure:
Max. 250mm WG (2500 Pa. or 10 inch WG)

Standard Color:
Aluminum

Acoustical Data:
For insertion loss data, please see page 272.

Fire Class:
Please see schedule on page 274.

Packing

Dia. Range		Std. Length (meters)	Carton Size (mm)
(mm)	(inches)		
102 - 305	(4" - 12")	10 meters	350 x 350 x 600
355	(14")	10 meters	350 x 350 x 750
405	(16")	10 meters	500 x 500 x 750
457	(18")	10 meters	500 x 500 x 750

Standard Length:
10 meters for all sizes (except 18" dia. L = 5M)

Description

SEMIDEC TK - A - a bendable, flexible corrugated aluminum duct suitable for low, medium & high pressure H.V.A.C. and Exhaust systems.

SEMIDEC TK - A, is supplied as standard in 3 meters long, compressed to 800mm for ease of transport and storage.

SEMIDEC TK - A can be easily extended, compressed, wound and bend to suit your requirements.

Ordering

Product Code: TKA - aaa

Type _____
diameter _____

TK - A



Construction and Dimensions

Construction:
Pure Aluminum - 100 microns

Diameter Range:
All standard diameters ranging from 76mm to 610mm.

Chemical Resistance:

- Good resistance to many solvents
- Moderate resistance to acid and base

Applications
SEMIDEC-TKA are appropriate for applications of general air supply, exhaust and return airconditioning and ventilation systems.

Mechanical and Technical Data

Minimum Bending Radius:
0.76 x Ø

Temperature Range:
-30 °C to + 250 °C

Air Velocity:
Max. 30 m/s (5900 ft/min)

Working Pressure
Max. 300mm WG (3000 Pa. or 12" WG)

Standard Color:
Aluminum

Fire Class:
Please see schedule on page 274.

Packing

Dia. Range		Std. Length (meters)	Carton Size (mm)
(mm)	(inches)		
102 - 178	(4" - 7")	3 meters	250 x 250 x 1200
200 - 305	(8" - 12")	3 meters	350 x 350 x 1200
355	(14")	3 meters	500 x 500 x 1200
405 - 508	(16" - 20")	3 meters	Loose
558 - 610	(22" - 24")	3 meters	Loose

Standard Length:
3 meters for all sizes compressed to 800mm for easy transport and storage.

THERMALLY INSULATED FLEXIBLE DUCT I ISO SEMIDEC TK - A - M

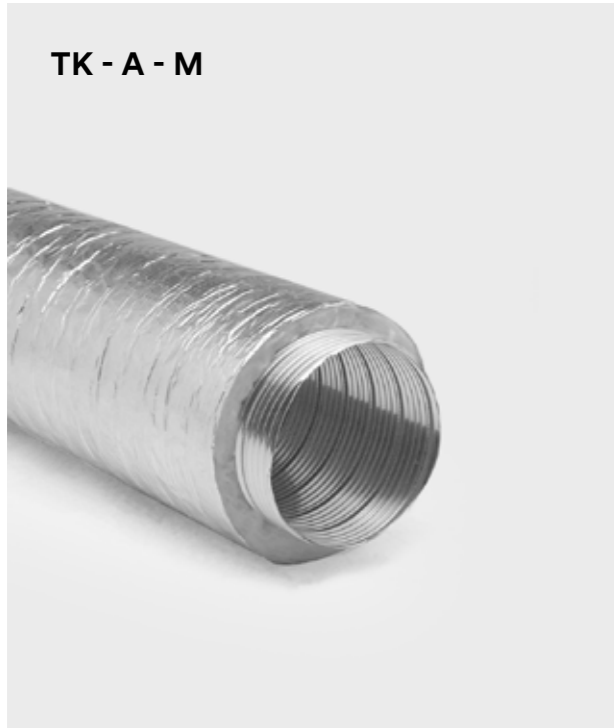

Description

ISO SEMIDEC (TK - A - M) - are thermally insulated ducts for various purposes. The inner core made of corrugated pure aluminum and outer jacket/vapour barrier constructed of multiple layer of aluminized polyester construction.

ISO SEMIDEC (TK - A - M) is suitable for low, medium, high pressure HVAC and exhaust systems. Standard ISO SEMIDEC is supplied in 3 meters lengths.

Ordering

Product Code: TKA-M-25 - aaa

Type _____
diameter _____

Construction and Dimensions

Construction:

Inner Duct: Corrugated Aluminum (TK - A)

Insulation:

25mm thick highly efficient fiberglass with a density of 16kg/m³.

50mm thick insulation also available upon request.

Vapour Barrier:

A durable, scuff resistant outerjacket made of strong very tough spirally reinforced multiple layer aluminized polyester construction.

Diameter Range:

All standard diameters ranging from 76mm to 457mm.

Chemical Resistance:

- Good resistance to many solvents
- Moderate resistance to acid and base

Applications:

ISO SEMIDEC TK - A - M are appropriate for applications of general air supply and airconditioning systems.

Mechanical and Technical Data

Minimum Bending Radius:

0.76 x Ø

Thermal Conductivity:

0.04 W/mK

Temperature Range:

Inner duct: -30 °C to + 250 °C.
Outer duct: -30 °C to + 140 °C.

Air Velocity:

Max. 30 m/s (5900 ft/min)

Working Pressure:

Max. 300mm WG (3000 Pa. or 12 inch WG)

Standard Color:

Aluminum

Fire Class:

Please see schedule on page 274.

Packing

Dia. Range		Std. Length (meters)
(mm)	(inches)	
102 - 178	(4" - 7")	3 meters
200 - 305	(8" - 12")	3 meters
355	(14")	3 meters
405	(16")	3 meters
457	(18")	3 meters

Standard Length:

3 meters for all sizes



ACOUSTICALLY INSULATED FLEXIBLE DUCT I SOUND ATTENUATORS

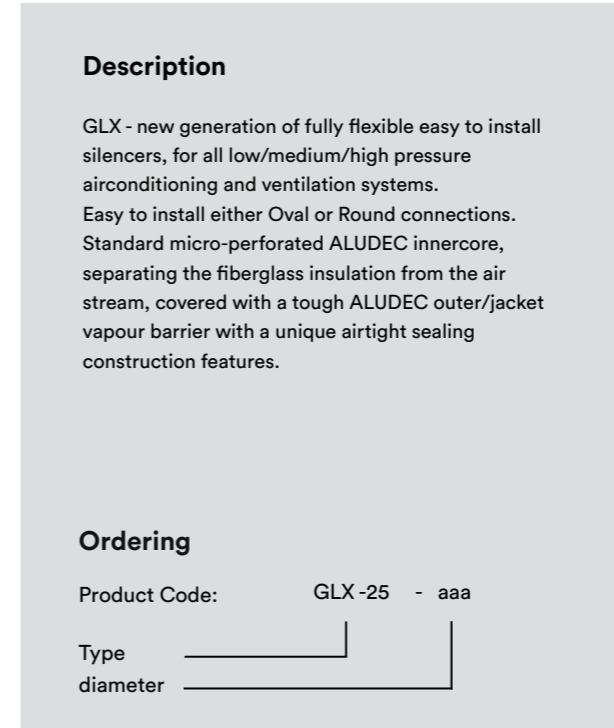

Description

GLX - new generation of fully flexible easy to install silencers, for all low/medium/high pressure airconditioning and ventilation systems.

Easy to install either Oval or Round connections. Standard micro-perforated ALUDEC innercore, separating the fiberglass insulation from the air stream, covered with a tough ALUDEC outer/jacket vapour barrier with a unique airtight sealing construction features.

Ordering

Product Code: GLX-25 - aaa

Type _____
diameter _____

Construction and Dimensions

Inner Core:

Perforated type ALUDEC Standard

Insulation:

25mm thick highly efficient fiberglass with a density of 16kg/m³.

Vapour Barrier:

ALUDEC Standard

Diameter Range:

All standard diameters ranging from 102mm to 457mm.

Diameter Range:

Inner duct - 18mm
Outer duct - 36mm

Chemical Resistance:

- Good resistance to many solvents
- Moderate resistance to acid and base

Applications:

GLX are appropriate for applications of general air supply and airconditioning systems.

Mechanical and Technical Data

Minimum Bending Radius:

0.58 x Ø

Thermal Conductivity:

0.04 W/mK



GLX - 25

Temperature Range:

-30 °C to + 140 °C

Air Velocity:

Max. 30 m/s (5900 ft/min)

Working Pressure:

Max. 300mm WG (3000 Pa. or 12 inch WG)

Standard Color

Aluminum

Acoustical Data:

For insertion loss data, please see page 273.

Fire Class:

Please see schedule on page 274.

Packing

Standard Length:

500mm - Packed into an individual carton
1000mm - Packed into an individual carton
1500mm - Packed into an individual carton
2000mm - Packed into an individual carton

Application Recommendations for Flexible Ducts

Recently the application of flexible ducting in air distribution systems has increased considerably. Knowledgeable application and skillful installation of the various types of flexible duct is therefore essential. Badly installed flexible ducts do have detrimental influences upon pressure losses in the air system. High, non-recoverable remedial costs are the inevitable penalties of attempting to enhance or replace a flexible duct system that was originally poorly installed.

Mounting Instructions

A-Support Hangers

Wherever possible flexible ducts should be installed in accordance with the manufacturers instructions. Should these be un-available, the following recommendations will generally result in a good installation.

- The flexible duct must be installed fully extended to produce optimum results, and accordingly this is the basis of all available pressure loss information in flexible ductwork products.
- The maximum allowable sag, between any two adjacent suspension points, should not exceed 50mm per metre. (Figure 1)
- The distance between any two adjacent suspension points may vary from 1.50 to 3.00 metres, dependent upon the type of flexible duct in use.

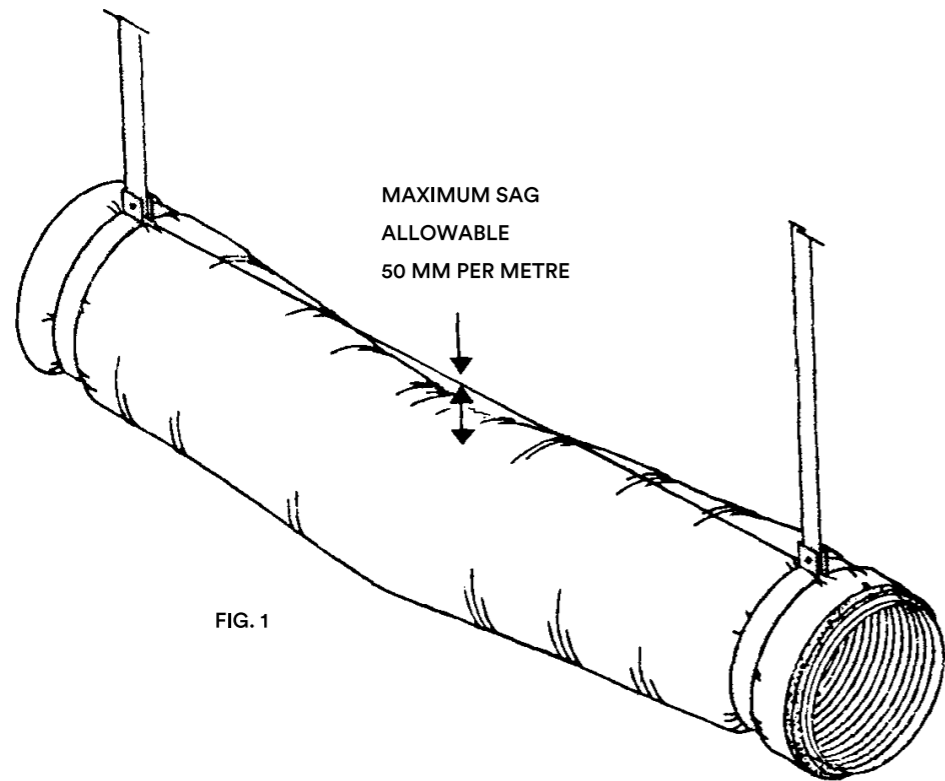

FIG. 1

Flexible ducts mounted above suspended ceilings should always be independently supported. Ducts mounted in these locations are susceptible to damaging whenever ceilings panels need to be periodically interchanged, unless they are separately supported.

B- Bending Radius

Minimum permissible radii are generally recommended by the manufacturer. (See Figure 2)

The following comparative dimensions can be recommended:

R = D for metal based products.

R = 0.8 x D for aluminium and plastic based products.

It is always advisable to make any bend radius as large as possible. This will reduce un-favourable pressure losses and is particularly important for metal based products which are more susceptible to stress rupturing. Double bends should be avoided, however if un-avoidable, ensure that each radius is not less than R=2 x D (See Figure 3).

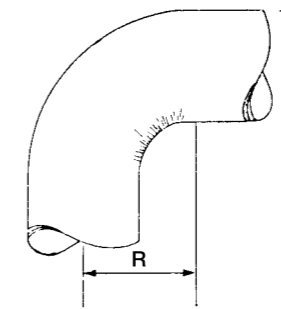

FIG. 2

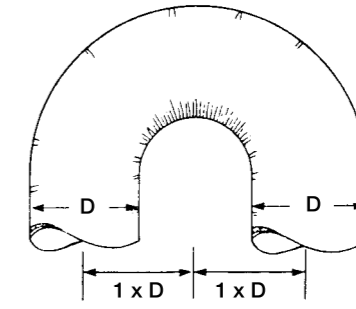

FIG. 3

C- Straps

Ideally the hanging straps should support the flexible duct with a minimum of half the circumference surface in contact, and without reducing the effective inside diameter of the duct. (See Figure 4 & 5). It is also recommended that the minimum width of material to be used for the hanging straps should be at least 25 mm.

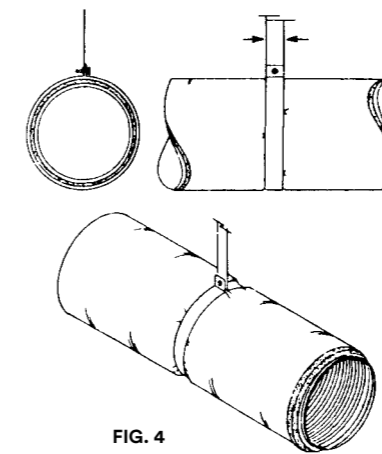

FIG. 4

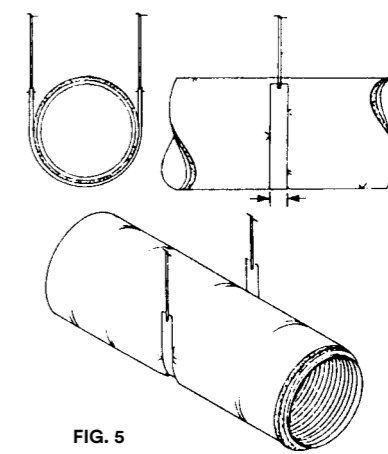
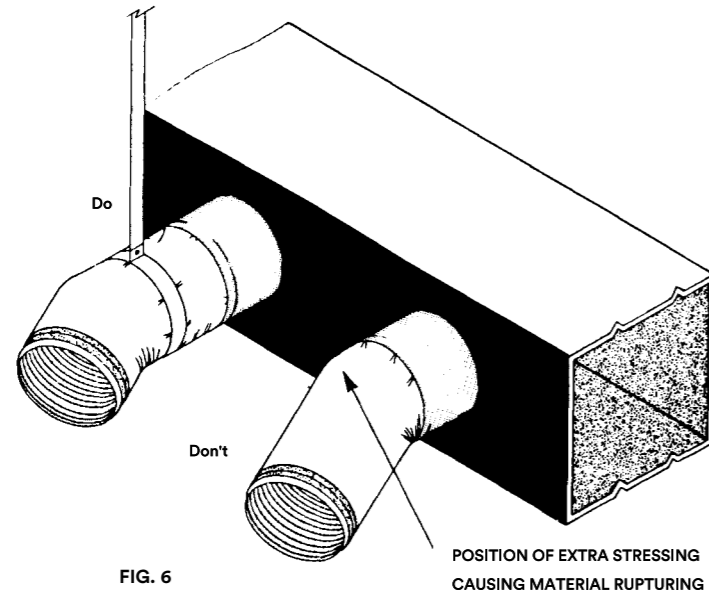

FIG. 5

D - Duct and Troffer Box Connections

Extra care should be taken when making flexible connections to fixed conventional ducts, etc. and ensure that they do not become too stressed. An additional support is recommended to obviate this problem. (See Figure 6)



Metal based flexible duct products are particularly prone to fracturing due to stress caused as a result of sharp connections. (figure 6) Connections to ceiling illumination “troffer boxes” should be served in the most direct manner similar to that described for conventional ducts. Too many bends, when connecting to “troffer boxes” and/or any other type of air supplying component, may result in excessive pressure loss and the generation of noise. Figure 7 illustrates a poor connection arrangement, and figure 8 shows the correct manner.

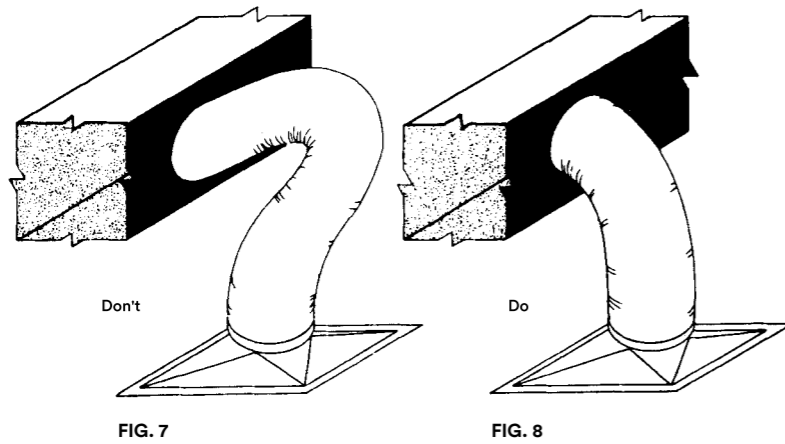

E- Practical Situations

During installation, many circumstances present themselves justifying the use of longer flexible duct sections. A typical example could be to “bridge-over” from one level to another, however certain limitations preclude the use of purpose prepared transformation sections. (Figure 9)

Or where space limitations are excessively restrictive, e.g. in a pipe or cable channel. Such cases are ideally solved by the skillful application of flexible duct. In the situation illustrated in figure 10, it should be emphasised that the flexible duct must not be in direct physical contact with un-insulated heating or hot process pipes.

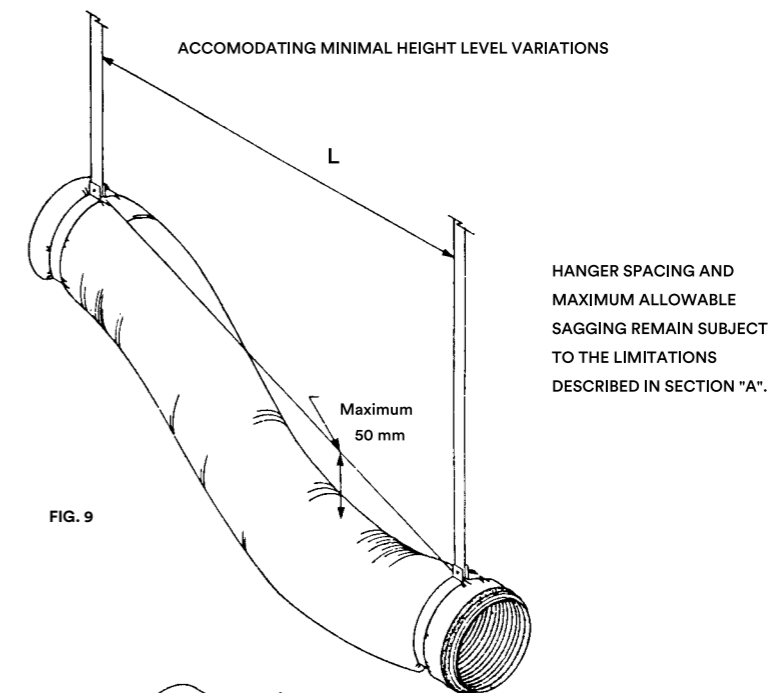

FIG. 9

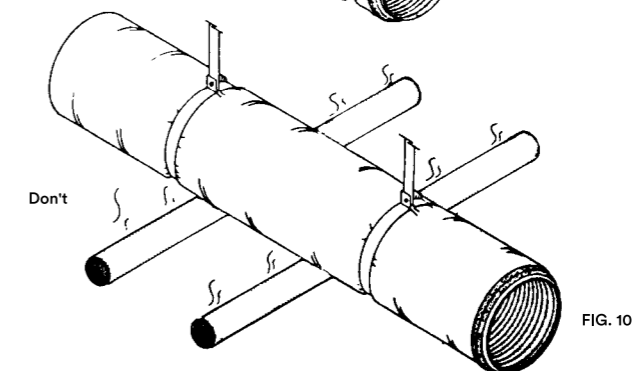
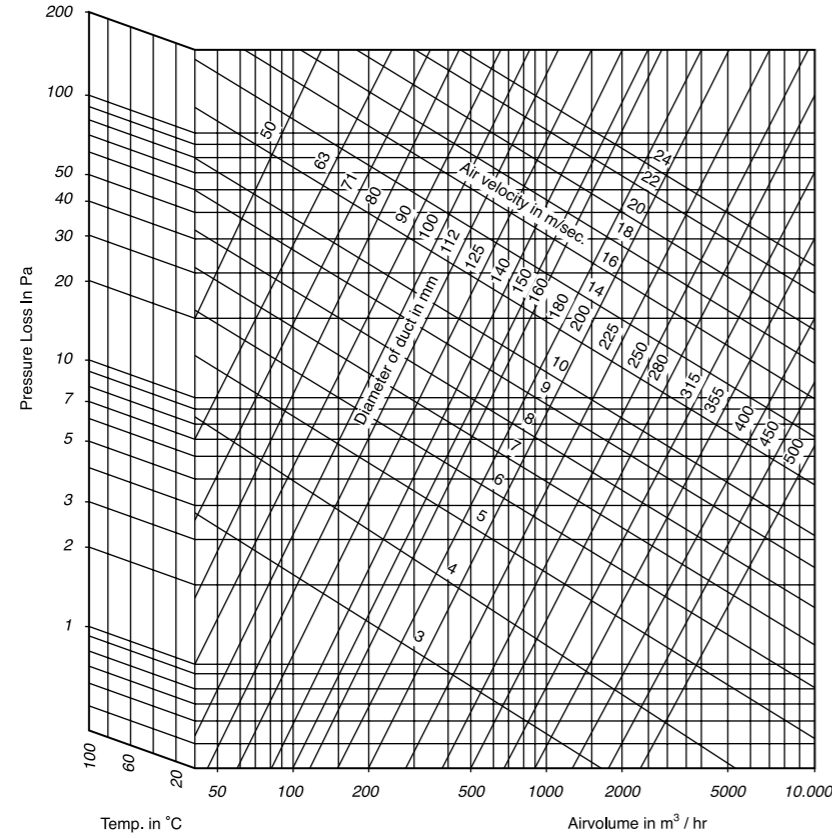

FIG. 10

These recommendations provide general procedures to most effectively satisfy many air distribution installations. Special or unconventional applications of flexible ducting should always be referred to the manufacturers representative or authorised dealer.

Pressure Loss Diagram



TK - A (SEMIDEC)

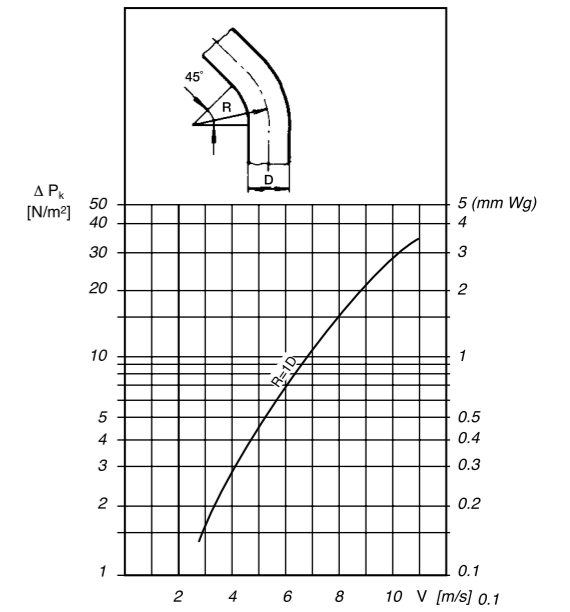
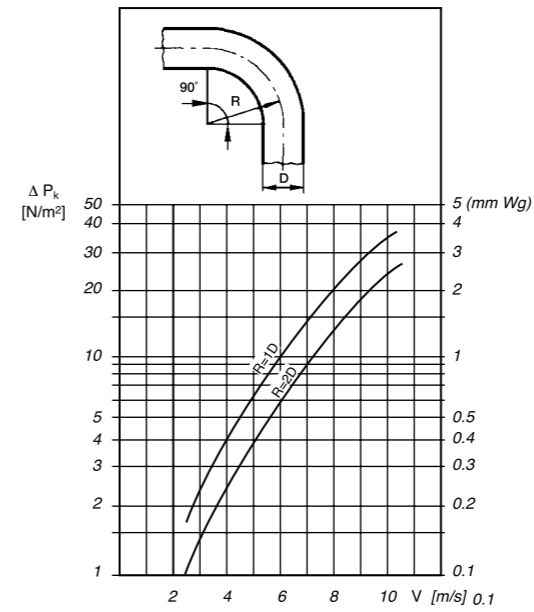
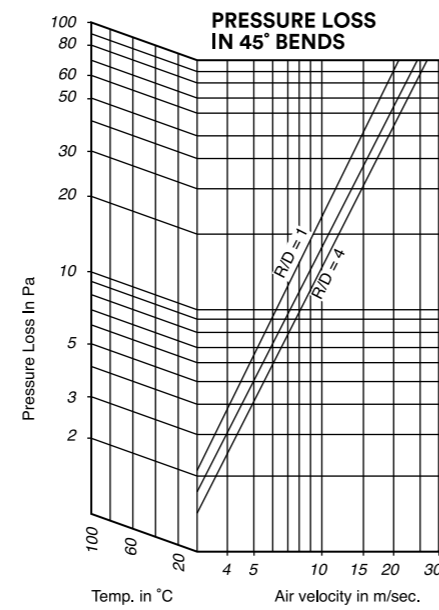
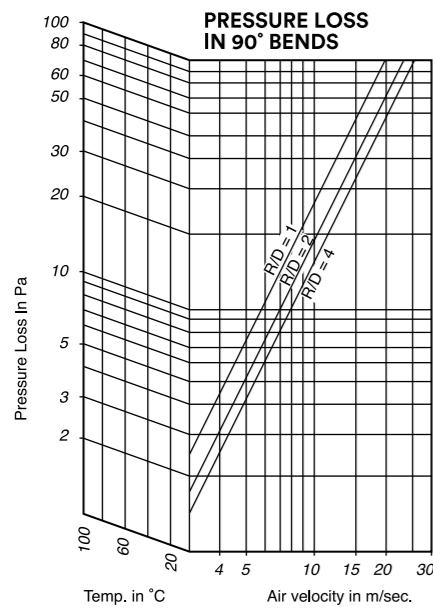
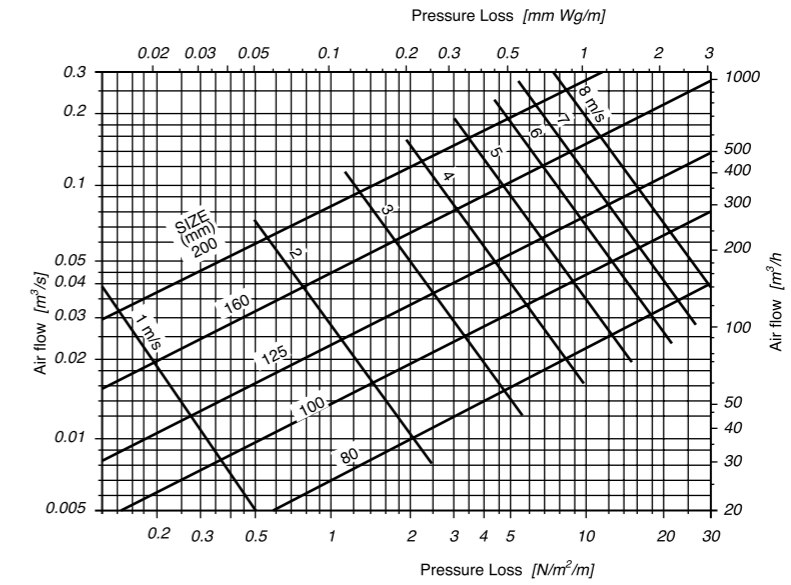

SONODEC - 25 Flexible Acoustic Ducting

INSERTION LOSS (in dB), calculated per 1 metre length of Acoustic Duct, through the Octave Band Frequencies 63 to 4000 Hz.

Freq. in Hz.	63*	125	250	500	1000	2000	4000
∅ 100 mm	6	10	22	28	30	24	40
∅ 125 mm	8	16	22	28	31	26	19
∅ 160 mm	8	7	18	25	25	25	17
∅ 250 mm	12	13	22	17	20	20	14

* Sound Testing Tolerance ± 2 dB.

INSERTION LOSS (in dB), calculated per 3 metre length of Acoustic Duct, through the Octave Band Frequencies 63 to 4000 Hz.

Freq. in Hz.	63*	125	250	500	1000	2000	4000
∅ 100 mm	9	18	26	30	31	26	22
∅ 125 mm	13	19	28	32	33	28	25
∅ 160 mm	7	13	30	36	34	30	29
∅ 250 mm	11	23	30	30	28	30	26

* Sound Testing Tolerance ± 2 dB.

General

The application of Acoustic Flexible Ducting and associated “break-out” noise needs to be considered at the H. V. A. C. design stage, as the Absorption Coefficient of the Insulation/Outer Jacket may allow a certain amount of noise emission into the surrounding air space. Therefore, Acoustic Flexible Ducting should be installed wherever possible over a Sound Absorbing Ceiling (Acousting Ceiling) or in an area of the building which will not be sensitive to “break-out” noise.

Test Results of “BREAK-OUT” NOISE (in dB), calculated per Metre length of Sonodec-25 Acoustic Duct, through the Octave Band Frequencies 63 to 4000 Hz.

INSERTION LOSS (in dB), calculated per 3 metre length of Acoustic Duct, through the Octave Band Frequencies 63 to 4000 Hz.

Freq. in Hz.	63*	125	250	500	1000	2000	4000
∅ 100 mm	4	3	5	6	9	10	11
∅ 125 mm	5	5	5	7	9	11	13
∅ 160 mm	8	8	8	9	9	10	14
∅ 250 mm	5	5	6	7	8	9	14

* Sound Testing Tolerance ± 2 dB.

GLX - 25 Sound Attenuators

INSERTION LOSS (in dB), calculated per 500 mm length of GLX 25 Sound Attenuators, through the Octave Band Frequencies 63 to 4000 Hz.

Freq. in Hz.	125	250	500	1000	2000	4000
∅ 100 mm	0	5	10	20	18	10
∅ 125 mm	0	5	10	21	24	14
∅ 160 mm	2	3	8	16	25	14
∅ 200 mm	2	3	8	13	9	8
∅ 250 mm	1	3	7	13	10	7

INSERTION LOSS (in dB), calculated per 1000 mm length of GLX 25 Sound Attenuators, through the Octave Band Frequencies 63 to 4000 Hz.

Freq. in Hz.	125	250	500	1000	2000	4000
∅ 100 mm	5	11	18	28	25	17
∅ 125 mm	3	6	18	30	26	19
∅ 160 mm	4	6	13	25	29	20
∅ 200 mm	4	6	14	25	17	14
∅ 250 mm	2	5	11	23	18	13

FIRE CLASS SCHEDULE



Fire Class	ALUDEC - 45	ALUDEC - 70	ISODEC - 25	ISODEC - 50	ISO SEMIDIC - 25
The Netherlands (NEN6065/6066)	1	1	1	1	1
Germany (DIN 4102)	B2	B2	B2	A2/B2	A1/B2
France (CSTB)	M1	x	M1	M0/M1	M0/M1
Switzerland (BKZ)	x	x	x	x	x
United Kingdom (BS 476)	7 & 20	7 & 20	6, 7 & 20	6, 7 & 20	6, 7 & 20
Austria (B 3800)	B1	B1	B1	B1	B1
Sweden (SP Fire 106)	x	x	x	x	x
Italy (CSI)	x	x	1-0	1-0	1-0
USA (UL 181)	x	x	UL 181, class 1	x	x

Fire Class	ISO - A - 25	SONODEC - 25	SONODEC - 50	SEMIDEC	GLX - 25
The Netherlands (NEN6065/6066)	x	1	1	1	1
Germany (DIN 4102)	x	B2	B2	A1	A2/B2
France (CSTB)	x	M1	M1	M0	M0/M1
Switzerland (BKZ)	x	x	x	6Q3	x
United Kingdom (BS 476)	x	6, 7 & 20	6, 7 & 20	4, 6 & 7	6, 7 & 20
Austria (B 3800)	x	B1	B1	A1	B1
Sweden (SP Fire 106)	x	x	x	A15 ²)	x
Italy (CSI)	x	1-0	1-0	0	0-0
USA (UL 181)	UL 181, class 1	x	x	x	x

x: not yet tested.

